

# GRC



## ROTARY PARALLEL PNEUMATIC GRIPPER

### Major Benefits

- High grip force to weight ratio
- Two body and jaw styles with a total of four sizes available in both imperial and metric versions
- Spring assist on open or close (available in two different forces)
- SHURGRIP option available for restraining jaw movement and part retention
- 1-2 day shipping
- 10 million cycles minimum rated life with standard seals (includes spring assist units)



U.S. Patent No. 4768821

GRC

SHURGRIP version restrains jaw movement and provides part retention upon loss of air pressure (licensed under U.S. Patent No. 4768821)

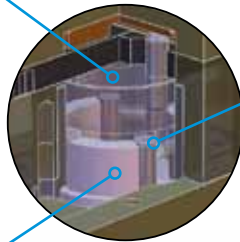

SHURGRIP with manual operation allows easy set up and adjustment of tooling by manual operation without air pressure

SHURGRIP components are made of hardened steel for long life with minimal wear

hardened steel jaws, available in 2 jaw styles, provide dowel holes for precise location of tooling

hardcoated aluminum body with precision dowel holes provides accurate gripper mounting

spring assist available for higher grip forces or part retention upon loss of air pressure

available in heavy or medium duty spring forces

large bore size provides high grip force to weight ratio

fluoro-elastomer seals are available for fluid compatibility

close tolerance jaw mechanism minimizes jaw play

hardened steel cam driver for high grip force and long life

hall, reed and proximity switches available for sensing jaw position

hardcoated aluminum rack and piston provide smooth operation and long life

# ORDERING DATA: SERIES GRC PARALLEL GRIPPERS

## TO ORDER SPECIFY:

Product Type, Series, Type, Style, Bore Size, Options, Design No., and Seals.

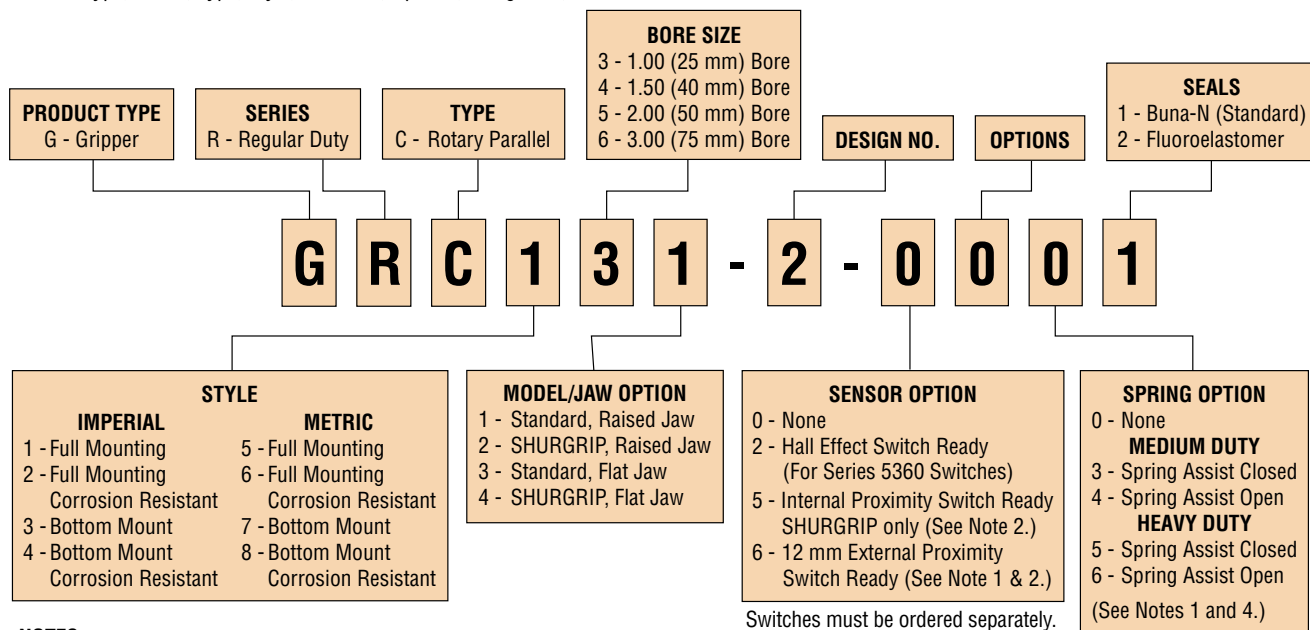

### NOTES:

- 1) Available on full mounting style only.
- 2) See Switch Mounting Kits on option pages.
- 3) See Switches and Sensors section for switch information.
- 4) Spring Assist Open option not available with -2 sensor option.

Switches must be ordered separately.  
See option pages for details.



Options may affect unit length. See dimensional pages and option information details.



Refer to this product's online catalog in the product section for complete information including related dimensions and additional specifications. See link at bottom of this page.

### HALL EFFECT SWITCHES

PART NO.	DESCRIPTION
53603-1-02	NPN (Sink) 4.5-24 VDC, 2 meter cable
53604-1-02	PNP (Source) 4.5-24 VDC, 2 meter cable
53623-1	NPN (Sink) 4.5-24 VDC, Quick Connect
53624-1	PNP (Source) 4.5-24 VDC, Quick Connect

**NOTE:** See Switches and Sensors section for additional switch information and complete specification. Switches must be ordered separately.

### INTERNAL PROXIMITY SWITCH READY

PART NO.	DESCRIPTION
18430-001-02	4 mm Round NPN (Sink) 2 m cable
18430-002-02	4 mm Round PNP (Source) 2 m cable
51422-005-02	8 mm Threaded NPN (Sink) 2 m cable
51422-006-02	8 mm Threaded PNP (Source) 2 m cable

### 12 mm EXTERNAL PROXIMITY SWITCH READY

PART NO.	DESCRIPTION
15561-001	NPN (Sink) 3 meter cable
15561-002	PNP (Source) 3 meter cable
15561-003	VAC Solid State



## CAD & Sizing Assistance

Use PHD's free online Product Sizing and CAD Configurator at [www.phdinc.com/myphd](http://www.phdinc.com/myphd)

# ENGINEERING DATA: SERIES GRC PARALLEL GRIPPERS

SPECIFICATIONS	SERIES GRC
OPERATING PRESSURE	
STANDARD UNIT	40 psi min to 100 psi max [2.8 bar min to 7 bar max] air
MEDIUM SPRING ASSIST UNIT	60 psi min to 100 psi max [4 bar min to 7 bar max] air
HEAVY SPRING ASSIST UNIT	72 psi min to 100 psi max [5 bar min to 7 bar max] air
MEDIUM SPRING ASSIST UNIT WITH SHURGRIP	65 psi min to 100 psi max [4.5 bar min to 7 bar max] air
HEAVY SPRING ASSIST UNIT WITH SHURGRIP	80 psi min to 100 psi max [5.5 bar min to 7 bar max] air
OPERATING TEMPERATURE	-20°F to +180°F [-28°C to +82°C]
RATED LIFE	10 million cycles minimum with standard seals (including spring assist units)
GRIP REPEATABILITY	Within ±0.002 in [±0.05 mm] of original centered position
CYCLE TIME	See table below
LUBRICATION	Factory lubricated for rated life
MAINTENANCE	Field repairable

GRIPPER NO.	MIN. TOTAL JAW TRAVEL		TOTAL GRIP FORCE AT 87 psi [6 bar]		GRIPPER WEIGHT (FLAT JAWS)		GRIPPER WEIGHT (RAISED JAWS)		CLOSE OR OPEN TIME 87 psi [6 bar]	MINIMUM OPERATING PRESSURE		DISPLACEMENT		GRIP FORCE FACTOR G <sub>F</sub>	
	in	mm	lb	N	lb	kg	lb	kg	sec	psi	bar	in <sup>3</sup>	cm <sup>3</sup>	IMPERIAL	METRIC
GRCx31 & 33	.940	24	96	427	1.68	0.76	1.81	0.82	.06	30	2	0.82	13.5	1.10	71.1
GRCx32 & 34	.940	24	83	369	2.32	1.05	2.45	1.11	.06	36	2.5	0.82	13.5	0.95	61.4
GRCx41 & 43	1.475	37.5	209	930	3.98	1.81	4.21	1.91	.08	30	2	2.77	45.5	2.4	155.2
GRCx42 & 44	1.475	37.5	178	792	5.34	2.42	5.57	2.53	.08	36	2.5	2.77	45.5	2.05	132.6
GRCx51 & 53	1.945	49.5	383	1704	7.35	3.33	7.89	3.58	.25	30	2	6.58	108.0	4.4	284.5
GRCx52 & 54	1.945	49.5	318	1414	10.52	4.77	11.1	5.02	.25	36	2.5	6.58	108.0	3.65	236.0
GRCx61 & 63	3.010	76.5	870	3870	20.47	9.28	21.7	9.85	.30	30	2	22.2	364.0	10	646.7
GRCx62 & 64	3.010	76.5	609	2709	28.2	12.79	29.4	13.4	.30	36	2.5	22.2	364.0	7	452.7

GRIPPER NO.	HEAVY SPRING							MEDIUM SPRING						
	SPRING GRIP FORCE S <sub>F</sub>		WEIGHT ADDER		CLOSE OR OPEN TIME 87 psi [6 bar] in seconds			SPRING GRIP FORCE S <sub>F</sub>		WEIGHT ADDER		CLOSE OR OPEN TIME 87 psi [6 bar] in seconds		
	lb	N	lb	kg	AGAINST SPRING	WITH SPRING	ONLY	lb	N	lb	kg	AGAINST SPRING	WITH SPRING	ONLY
GRCx31 & 33	51	227	0.67	0.3	.10	.05	.08	35	156	0.60	0.27	.08	.05	.10
GRCx32 & 34	44	196	0.67	0.3	.10	.05	.08	30	133	0.60	0.27	.08	.05	.10
GRCx41 & 43	110	489	1.69	0.8	.16	.06	.10	78	347	1.43	0.65	.12	.07	.14
GRCx42 & 44	93	414	1.69	0.8	.16	.06	.10	66	294	1.43	0.65	.12	.07	.14
GRCx51 & 53	204	907	3.48	1.6	.35	.15	.30	140	623	2.88	1.31	.30	.20	.35
GRCx52 & 54	170	756	3.48	1.6	.35	.15	.30	117	520	2.88	1.31	.30	.20	.35
GRCx61 & 63	465	2068	9.5	4.3	.50	.20	.35	312	1388	7.81	3.54	.40	.25	.50
GRCx62 & 64	320	1423	9.5	4.3	.50	.20	.35	215	956	7.81	3.54	.40	.25	.50



## Sizing & Application Assistance

Use PHD's free online Product Sizing Application or view the Product Sizing Catalog at: [www.phdinc.com/apps/sizing](http://www.phdinc.com/apps/sizing)

## GRIP FORCE CALCULATION EQUATIONS:

### IMPERIAL:

**TOTAL GRIP FORCE [lb] = (Pressure [psi] x G<sub>F</sub>) x Jaw Position Factor x Tooling Length Factor**

**TOTAL GRIP FORCE WITH SPRINGS [lb] = ((Pressure [psi] x G<sub>F</sub>) ± S<sub>F</sub> [lb]) x Jaw Position Factor x Tooling Length Factor**

### METRIC:

**TOTAL GRIP FORCE [N] = (Pressure [bar] x G<sub>F</sub>) x Jaw Position Factor x Tooling Length Factor**

**TOTAL GRIP FORCE WITH SPRINGS [N] = ((Pressure [bar] x G<sub>F</sub>) ± S<sub>F</sub> [N]) x Jaw Position Factor x Tooling Length Factor**

## JAW POSITION FACTOR GRAPH

The Series GRC Gripper mechanism increases grip force as the jaws move away from midposition toward open or closed position. Tooling can be designed to take advantage of the higher forces available when the jaws are close to the end positions. The chart shows how force increases as the jaws move toward the end positions. The grip forces should be multiplied by the jaw position factor for an accurate grip force calculation.

**JAW POSITION FACTOR BASED ON DIMENSION "A" ACROSS GRIPPER JAWS**

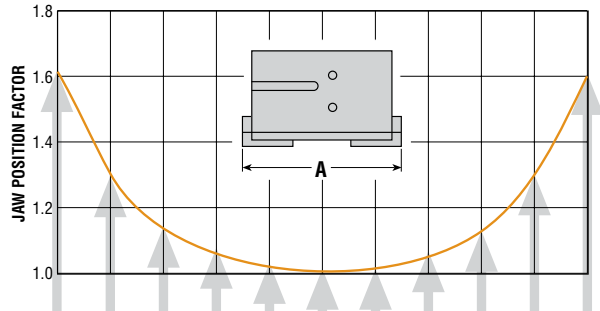

GRIPPER MODEL	DIMENSION "A" inches [mm]										
GRCx31 & 33	4.685	4.785	4.885	4.985	5.085	5.185	5.285	5.385	5.485	5.585	5.685
GRCx32 & 34	[119.0]	[121.5]	[124.1]	[126.6]	[129.2]	[131.7]	[134.3]	[136.8]	[139.4]	[141.9]	[144.5]
GRCx41 & 43	6.200	6.354	6.507	6.660	6.814	6.967	7.120	7.274	7.427	7.581	7.735
GRCx42 & 44	[157.5]	[161.4]	[165.3]	[169.2]	[173.1]	[177.0]	[180.9]	[184.8]	[188.7]	[192.6]	[196.4]
GRCx51 & 53	7.520	7.720	7.920	8.120	8.320	8.520	8.720	8.920	9.120	9.320	9.525
GRCx52 & 54	[191.0]	[196.1]	[201.2]	[206.3]	[211.4]	[216.5]	[221.6]	[226.7]	[231.8]	[236.9]	[242.0]
GRCx61 & 63	10.315	10.622	10.929	11.236	11.543	11.850	12.157	12.464	12.771	13.078	13.385
GRCx62 & 64	[262.0]	[269.8]	[277.6]	[285.4]	[293.2]	[301.0]	[308.8]	[316.6]	[324.4]	[332.2]	[340.0]

## TOOLING LENGTH FACTOR

Design tooling so that the grip point is as close to the cover surface as possible. When the grip point moves away, jaw friction increases, which decreases grip force. The G<sub>F</sub> information given on page 4-51 is for zero tooling length (cover surface). The graph shows how force decreases as the grip point moves away from the cover surface.

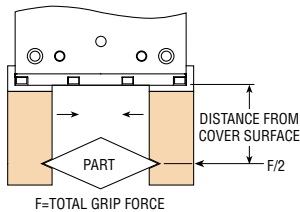

**TOOLING LENGTH FACTOR**

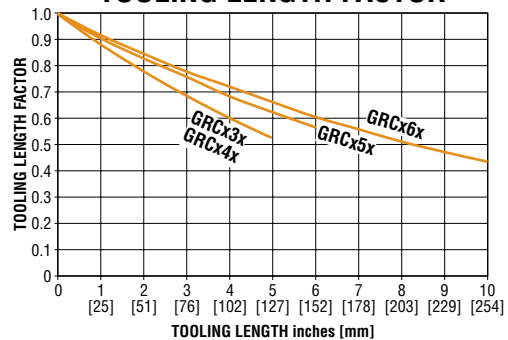

## FLAT JAW TOOLING

Special attention should be paid to the distance the fasteners extend through the flat jaw. If they extend through more than G dimension and come in contact with the body, damage to the gripper cover or jaw may occur. Tooling counterbores, fastener length and tolerances should be specified so that the fastener fully engages the jaw and nominally extends through .05 inch [1.25 mm] with a tolerance of  $\pm .03$  inch [ $\pm .75$  mm]. This assures a distance of G dimension is never reached.

The flat jaw provides two threads for mounting tooling and a precision hole closely located from the end of the jaw. Customers can key tooling using the end of the jaw and precision hole to provide squareness and location. See pages 4-54 and 4-55 for maximum recommended tooling dimensions (dimensions F8 and F10).

LETTER DIM.	MODEL NUMBER							
	GRCx3x		GRCx4x		GRCx5x		GRCx6x	
F12	.184	4.7	.258	6.6	.317	8.1	.436	11.1
G MIN	.098	2.5	.120	3.0	.120	3.0	.245	6.2

### NOTES:

- 1) MOUNTING SCREWS MUST PROTRUDE PAST BOTTOM OF JAW TO ENSURE MAXIMUM THREAD ENGAGEMENT
- 2) MOUNTING SCREWS MUST NOT EXCEED RECOMMENDED DEPTH OF ENGAGEMENT OR COME IN CONTACT WITH BOTTOM OF BODY

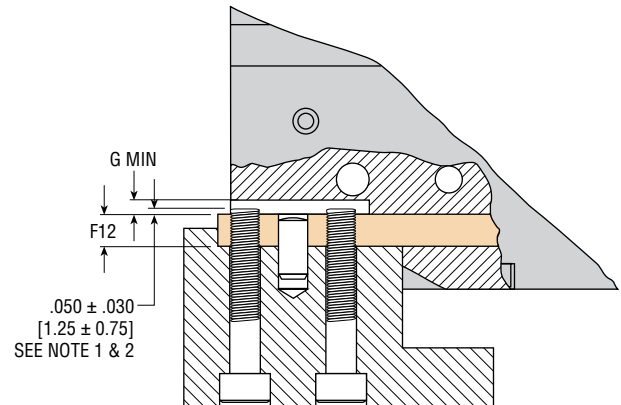

## RAISED JAW TOOLING

The boss on raised jaws (dimensions R8 and R10) are held to a close tolerance. These surfaces can be used as a means of orienting and precisely keying the tooling to the gripper jaws. Dowel pin holes in the jaws can also be used for precise tooling location. See pages 4-54 and 4-55 for specific jaw dimensions.

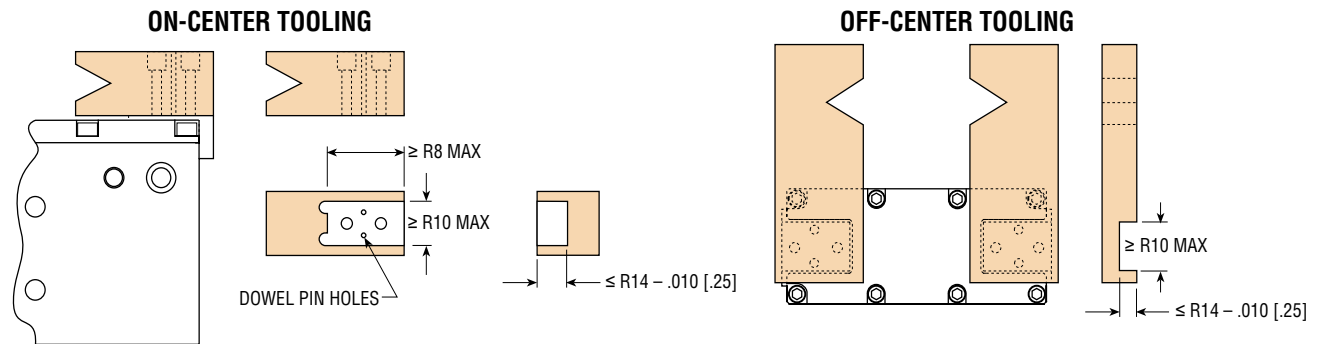

All dimensions are reference only unless specifically toleranced.

# DIMENSIONS: STANDARD SERIES GRC PARALLEL GRIPPERS

## FULL MOUNTING STYLE

GRC1xx  
GRC2xx  
GRC5xx  
GRC6xx



### CAD & Sizing Assistance

Use PHD's free online Product Sizing and CAD Configurator at [www.phdinc.com/myphd](http://www.phdinc.com/myphd)

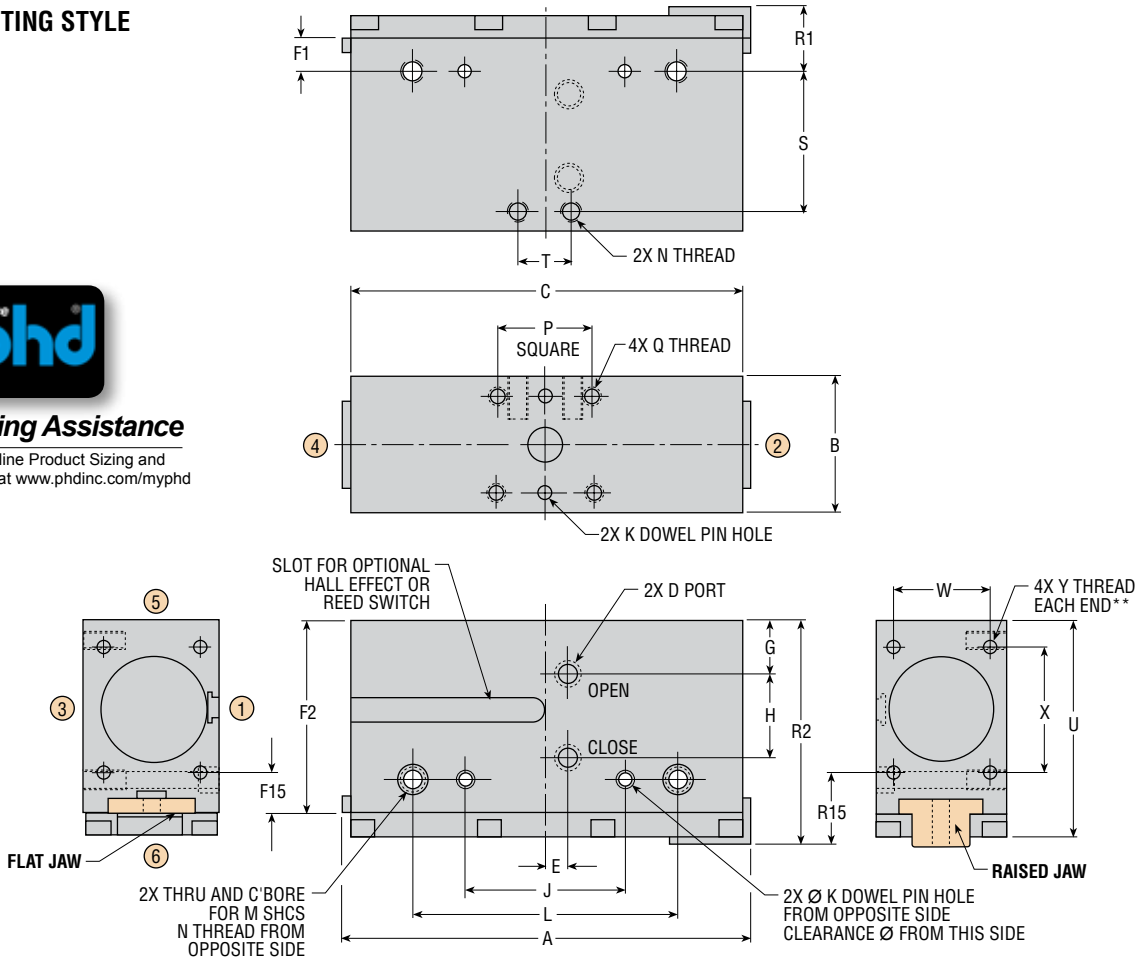

UNITS ARE SHOWN WITH 1 FLAT AND 1 RAISED JAW. UNITS ARE AVAILABLE ONLY WITH 2 FLAT OR RAISED JAWS.

\*\*NOT RECOMMENDED FOR GRIPPER MOUNTING UNLESS BOTH ENDS ARE USED.

CIRCLED NUMBERS INDICATE SURFACE POSITIONS.

## BOTTOM MOUNTING STYLE

GRC3xx  
GRC4xx  
GRC7xx  
GRC8xx

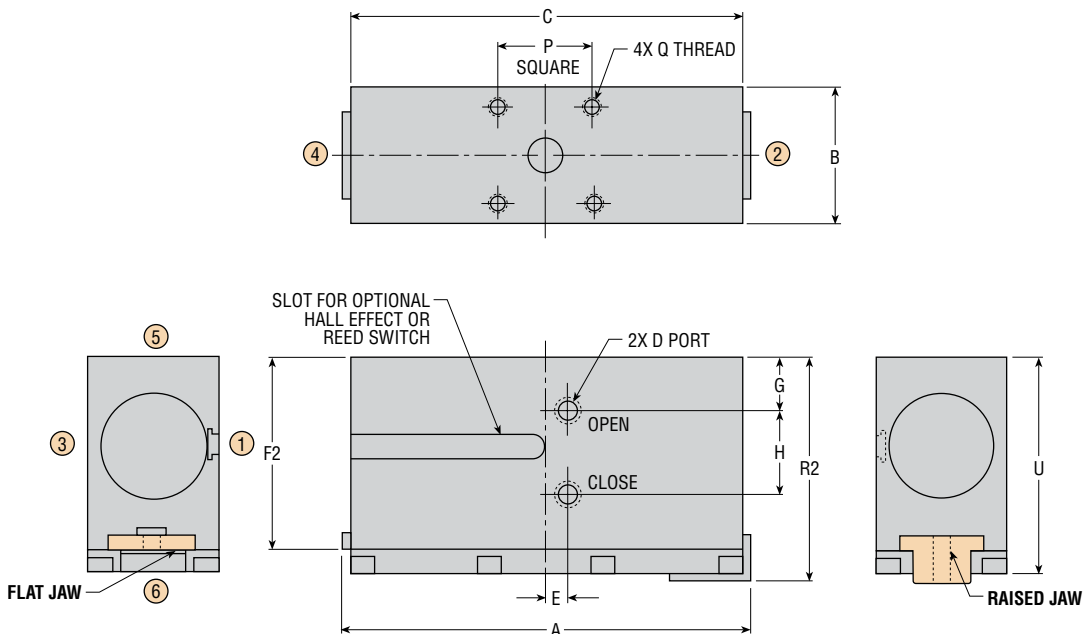

All dimensions are reference only unless specifically tolerated.

[www.phdinc.com/grc](http://www.phdinc.com/grc) • (800) 624-8511



# DIMENSIONS: STANDARD SERIES GRC PARALLEL GRIPPERS

LETTER DIM.	MODEL NO.							
	GRCx3x		GRCx4x		GRCx5x		GRCx6x	
	in	mm	in	mm	in	mm	in	mm
NOMINAL JAW TRAVEL	1.00	25.5	1.53	39	2.00	51	3.07	78
A CLOSED *	4.715	119.7	6.230	158.2	7.550	191.7	10.345	262.70
A OPEN *	5.655	143.6	7.705	195.8	9.495	241.2	13.355	339.2
B	1.575	40.0	2.046	52.0	2.638	67.0	3.936	100.0
C	4.570	116.0	6.004	152.5	7.320	186.0	10.080	256.0
D	10-32	M5 x 0.8	1/8 NPT	1/8 BSP	1/8 NPT	1/8 BSP	1/4 NPT	1/4 BSP
E	.354	9.0	.354	9.0	.551	14.0	—	—
G	.630	16.0	.820	21.0	1.004	25.5	1.030	26.0
H	.910	23.0	1.299	33.0	1.535	39.0	2.559	65.0
J*	1.654	42.00	2.441	62.00	3.150	80.00	4.724	120.00
K*	.1884 x .25 DP	5.02 x 6.0	.1884 x .310 DP	5.02 X 8.0	.2509 x .350 DP	6.02 x 9.0 DP	.3759 x .450 DP	10.02 x 12.0 DP
L	2.953	75.0	4.016	102.0	5.905	150.0	7.874	200.0
M	#10	M5	1/4	M6	5/16	M8	3/8	M10
N	1/4-20 x .47 DP	M6 x 1.0 x 12 DP	5/16-18 x .630	M8 X 1.25 x 16.0 DP	3/8-16 x .750 DP	M10 x 1.5 x 19.0	1/2-13 x 1.000 DP	M14 x 2.0 x 28.0 DP
P*	1.1810	30.00	1.4570	37.00	1.9680	50.00	2.9920	76.00
Q	10-24 x .38 DP	M5 x 0.8 x 9.5 DP	1/4-20 x .500	M6 x 1.0 x 12.0 DP	5/16-18 x .630 DP	M8 x 1.25 x 16.0 DP	3/8-16 x .750 DP	M10 x 1.5 x 19.0
S	1.614	41.0	2.165	55.0	2.678	68.0	3.740	95.0
T	.630	16.0	.826	21.0	1.063	27.0	1.890	48.0
U	2.556	65.0	3.370	85.5	4.148	105.5	5.767	146.5
W	1.162	29.5	1.496	38.0	2.008	51.0	3.071	78.0
X	1.378	35.0	1.929	49.0	2.244	57.0	3.071	78.0
Y	M4 x 0.7 x .32 DP	M4 x 0.7 x 8.0 DP	M5 x 0.8 x .350 DP	M5 x 0.8 x 9.0 DP	M6 x 1.0 x .411 DP	M6 x 1.0 x 10.5 DP	M8 x 1.25 x .630 DP	M8 x 1.25 x 16.0 DP
F1	.415	10.5	.555	14.0	.671	17.0	.984	25.0
F2	2.284	58.0	3.018	76.75	3.696	94.0	5.156	131.0
F3*	.551	14.0	.610	15.5	.768	19.5	1.023	26.0
F4	.354	9.0	.394	10.0	.492	12.5	.689	17.5
F5	.709	18.0	.788	20.0	.984	25.0	1.378	35.0
F6*	.1884	5.02	.2509	6.02	.3134	8.02	.5009	12.02
F7	10-24	M5 x 0.8	1/4-20	M6 x 1.0	5/16-18	M8 x 1.25	3/8-16	M10 x 1.5
F8	1.102	28.0	1.220	31.0	1.535	39.0	2.047	52.0
F10	.591	15.0	.886	22.5	1.122	28.5	1.968	50.0
F11	.934	23.75	1.284	32.5	1.748	44.5	2.830	72.0
F12	.184	4.75	.258	6.5	.317	8.0	.436	11.0
F13	.100	2.5	.125	3.0	.125	3.0	.250	6.25
F14	.272	7.0	.352	9.0	.451	11.5	.611	15.5
F15	.605	15.5	.683	17.5	.954	24.25	1.415	36.0
R1	.788	20.0	1.007	25.5	1.221	31.0	1.713	43.5
R2	2.657	67.5	3.470	88.0	4.246	108.0	5.885	149.5
R3	.551	14.0	.610	15.5	.768	19.5	1.023	26.0
R4	.354	9.0	.394	10.0	.492	12.5	.689	17.5
R5	.709	18.0	.788	20.0	.984	25.0	1.378	35.0
R6*	.1259 x .250 DP	4.02 x 6.0 DP	.1884 x .320 DP	5.02 x 8.0 DP	.2509 x .370 DP	6.02 x 9.0 DP	.3759 x .560 DP	10.02 X 14.0
R7	10-24 x .380 DP	M5 x 0.8 x 9.5 DP	1/4-20 x .500 DP	M6 x 1.0 x 12.5 DP	5/16-18 x .630 DP	M8 x 1.25 x 16.0 DP	3/8-16 x .787 DP	M10 x 1.5 x 20.0 DP
R8*	1.102	28.0	1.220	31.0	1.535	39.0	2.047	52.0
R9*	.2953	7.5	.5512	14.0	.7086	18.0	1.2992	33.0
R10*	.5906	15.00	.8858	22.50	1.1220	28.50	1.9685	50.00
R11	.934	23.75	1.284	32.5	1.748	44.50	2.830	72.0
R12	.557	14.25	.710	18.0	.866	22.0	1.165	29.5
R14	.101	2.5	.100	2.5	.098	2.5	.118	3.0
R15	.976	24.75	1.134	28.75	1.502	38.25	2.143	54.5

NOTE: \*TOLERANCE FOR DIMENSIONS: J = ± .0010 [±0.03] K = ± .0005 [±0.013] P (BETWEEN DOWEL PIN HOLES) = ± .0008 [±0.02]  
F6 AND R6 = ± .0005 [±0.013] F3, R9, AND R10 = ± .0010 [±0.03] R8 = ± .005 [±0.13]

\*A CLOSED REFLECTS THE LARGEST POSSIBLE CLOSED DIMENSION.  
A OPEN REFLECTS THE SMALLEST POSSIBLE OPEN DIMENSION.

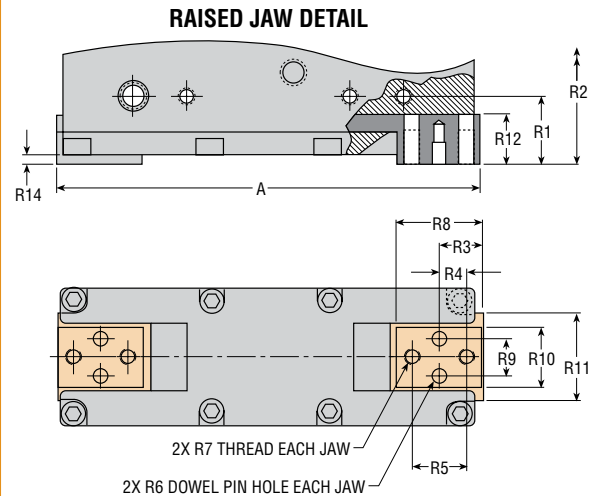
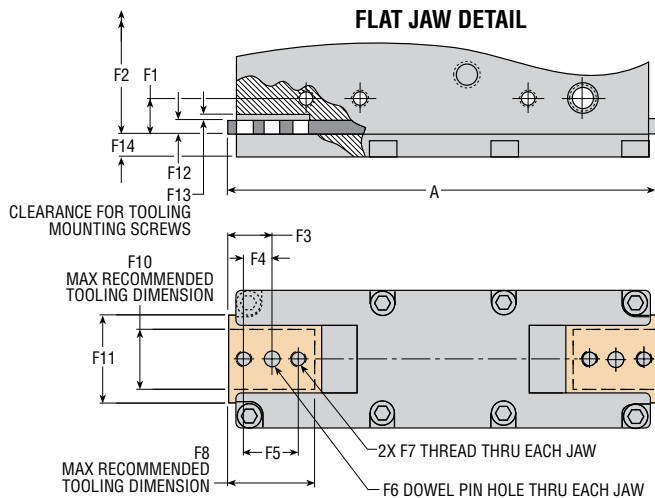

All dimensions are reference only unless specifically tolerated.



# DIMENSIONS: SHURGRIP SERIES GRC PARALLEL GRIPPERS

## FULL MOUNTING STYLE

- GRC1xx
- GRC2xx
- GRC5xx
- GRC6xx



### CAD & Sizing Assistance

Use PHD's free online Product Sizing and CAD Configurator at [www.phdinc.com/myphd](http://www.phdinc.com/myphd)

GRC

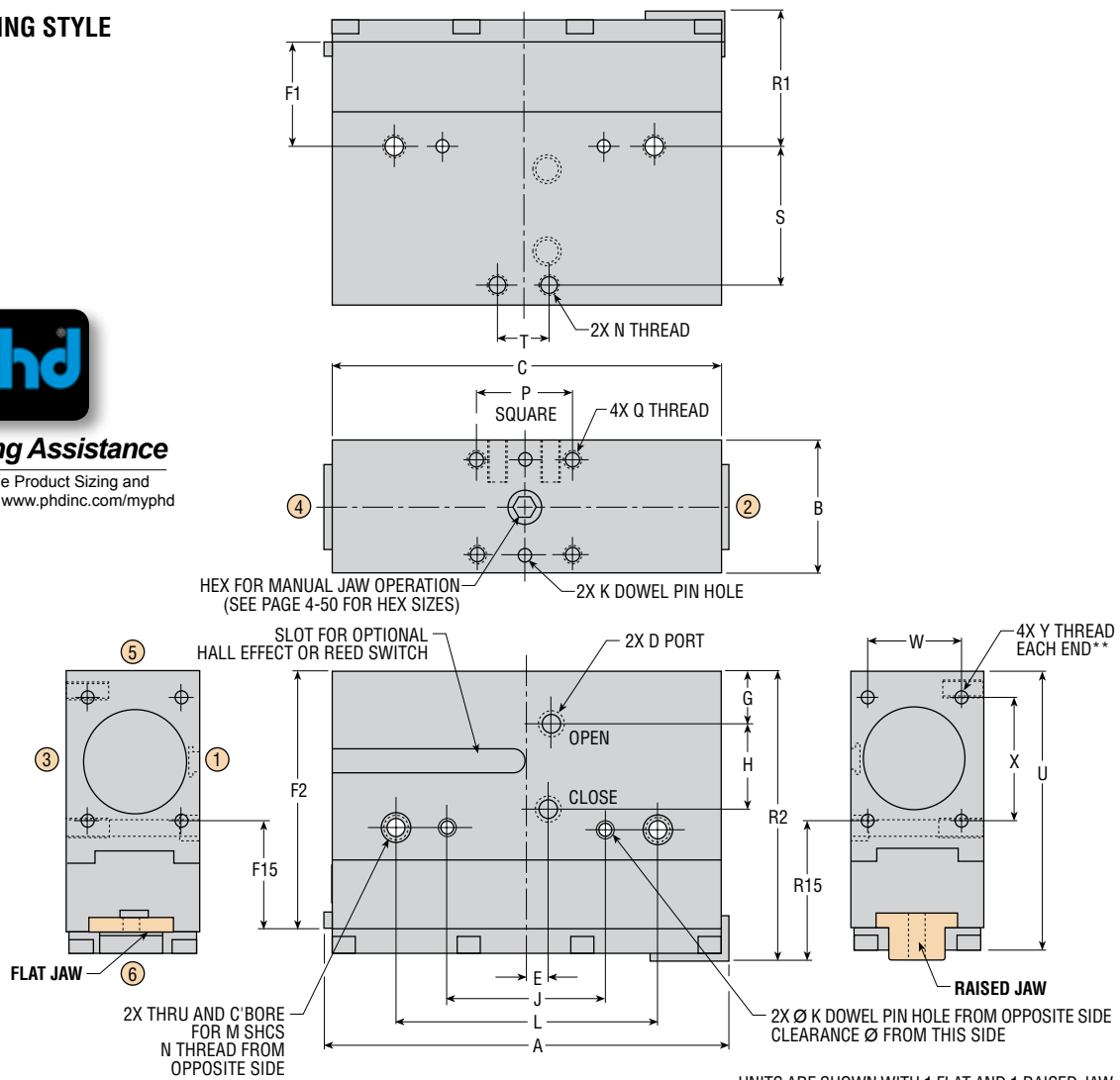

UNITS ARE SHOWN WITH 1 FLAT AND 1 RAISED JAW. UNITS ARE AVAILABLE ONLY WITH 2 FLAT OR RAISED JAWS.

\*\*NOT RECOMMENDED FOR GRIPPER MOUNTING UNLESS BOTH ENDS ARE USED.

CIRCLED NUMBERS INDICATE SURFACE POSITIONS.

## BOTTOM MOUNTING STYLE

- GRC3xx
- GRC4xx
- GRC7xx
- GRC8xx

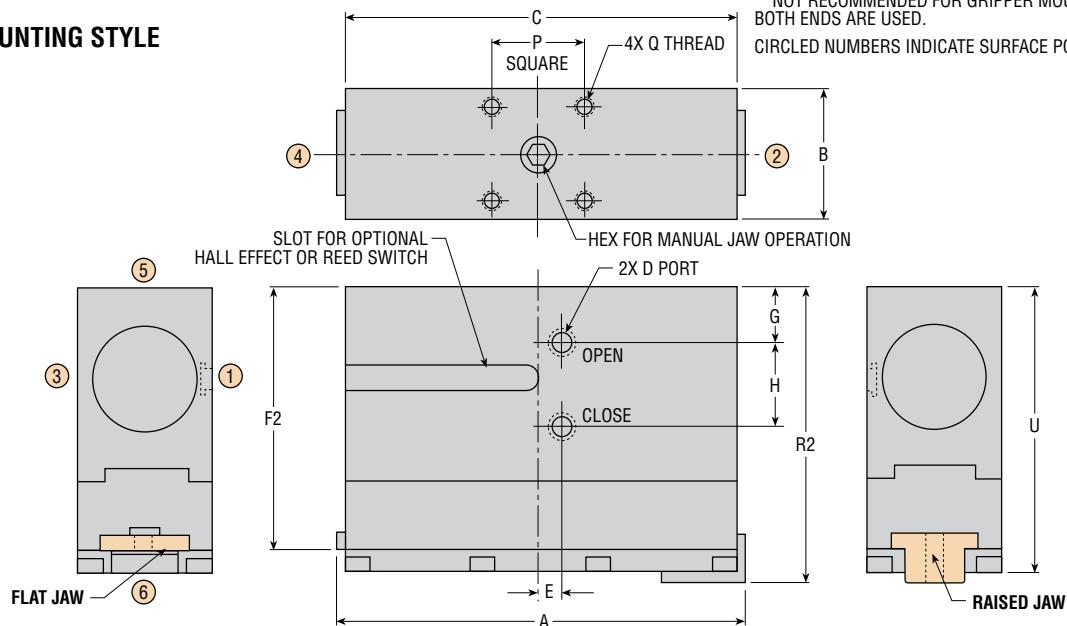

All dimensions are reference only unless specifically tolerated.

[www.phdinc.com/grc](http://www.phdinc.com/grc) • (800) 624-8511



# DIMENSIONS: SHURGRIP SERIES GRC PARALLEL GRIPPERS

LETTER DIM	MODEL NO.							
	GRCx3x		GRCx4x		GRCx5x		GRCx6x	
	in	mm	in	mm	in	mm	in	mm
NOMINAL JAW TRAVEL	1.00	25.5	1.53	39	2.00	51	3.07	78
A CLOSED *	4.715	119.7	6.230	158.2	7.550	191.7	10.345	262.7
A OPEN *	5.655	143.6	7.705	195.8	9.495	241.2	13.355	339.2
B	1.575	40.0	2.046	52.0	2.638	67.0	3.936	100.0
C	4.570	116.0	6.004	152.5	7.320	186.0	10.080	256.0
D	10-32	M5 x 0.8	1/8 NPT	1/8 BSP	1/8 NPT	1/8 BSP	1/4 NPT	1/4 BSP
E	.354	9.0	.354	9.0	.511	14.0	—	—
G	.630	16.0	.820	21.0	1.004	25.5	1.030	26.0
H	.910	23.0	1.299	33.0	1.535	39.0	2.559	65.0
J**	1.654	42.00	2.441	62.00	3.150	80.00	4.724	120.00
K**	.1884 x .25 DP	5.02 x 6.0	.1884 x .310 DP	5.02 X 8.0	.2509 x .350 DP	6.02 x 9.0 DP	.3759 x .450 DP	10.02 x 12.0 DP
L	2.953	75.0	4.016	102.0	5.905	150.0	7.874	200.0
M	#10	M5	1/4	M6	5/16	M8	3/8	M10
N	1/4-20 x .47 DP	M6 x 1.0 x 12 DP	5/16-18 x .630	M8 X 1.25 x 16.0 DP	3/8-16 x .750 DP	M10 x 1.5 x 19.0	1/2-13 x 1.000 DP	M14 x 2.0 x 28.0 DP
P**	1.1810	30.00	1.4570	37.00	1.9680	50.00	2.9920	76.00
Q	10-24 x .38 DP	M5 x 0.8 x 9.5 DP	1/4-20 x .500	M6 x 1.0 x 12.0 DP	5/16-18 x .630 DP	M8 x 1.25 x 16.0 DP	3/8-16 x .750 DP	M10 x 1.5 x 19.0
S	1.614	41.0	2.165	55.0	2.678	68.0	3.740	95.0
T	.630	16.0	.826	21.0	1.063	27.0	1.890	48.0
U	3.323	84.5	4.432	112.5	5.604	142.5	7.735	196.5
W	1.162	29.5	1.496	38.0	2.008	51.0	3.071	78.0
X	1.378	35.0	1.929	49.0	2.244	57.0	3.071	78.0
Y	M4 x 0.7 x .32 DP	M4 x 0.7 x 8.0 DP	M5 x 0.8 x .350 DP	M5 x 0.8 x 9.0 DP	M6 x 1.0 x .411 DP	M6 x 1.0 x 10.5 DP	M8 x 1.25 x .630 DP	M8 x 1.25 x 16.0 DP
F1	1.182	30.0	1.617	41.0	2.127	54.0	2.952	75.0
F2	3.051	77.5	4.080	103.5	5.153	131.0	7.124	181.0
F3**	.551	14.0	.610	15.5	.768	19.5	1.023	26.0
F4	.354	9.0	.394	10.0	.492	12.5	.689	17.5
F5	.709	18.0	.788	20.0	.984	25.0	1.378	35.0
F6**	.1884	5.02	.2509	6.02	.3134	8.02	.5009	12.02
F7	10-24	M5 x 0.8	1/4-20	M6 x 1.0	5/16-18	M8 x 1.25	3/8-16	M10 x 1.5
F8	1.102	28.0	1.220	31.0	1.535	39.0	2.047	52.0
F10	.591	15.0	.886	22.5	1.122	28.5	1.968	50.0
F11	.934	23.75	1.284	32.5	1.748	44.5	2.830	72.0
F12	.184	4.75	.258	6.5	.317	8.0	.436	11.0
F13	.100	2.5	.125	3.0	.125	3.0	.250	6.25
F14	.272	7.0	.352	9.0	.451	11.5	.611	15.5
F15	1.372	35.0	1.745	44.25	2.410	61.25	3.383	86.0
R1	1.555	39.5	2.068	52.5	2.667	68.0	3.681	93.5
R2	3.424	87.0	4.532	115.0	5.702	145.0	7.853	199.5
R3	.551	14.0	.610	15.5	.768	19.5	1.023	26.0
R4	.354	9.0	.394	10.0	.492	12.5	.689	17.5
R5	.709	18.0	.788	20.0	.984	25.0	1.378	35.0
R6**	.1259 x .250 DP	4.02 x 6.0 DP	.1884 x .320 DP	5.02 x 8.0 DP	.2509 x .370 DP	6.02 x 9.0 DP	.3759 x .560 DP	10.02 x 14.0
R7	10-24 x .380 DP	M5 x 0.8 x 9.5 DP	1/4-20 x .500 DP	M6 x 1.0 x 12.5 DP	5/16-18 x .630 DP	M8 x 1.25 x 16.0 DP	3/8-16 x .787 DP	M10 x 1.5 x 20.0 DP
R8**	1.102	28.0	1.220	31.0	1.535	39.0	2.047	52.0
R9**	.2953	7.5	.5512	14.0	.7086	18.0	1.2992	33.0
R10**	.5906	15.00	.8858	22.50	1.1220	28.50	1.9685	50.00
R11	.934	23.75	1.284	32.5	1.748	44.50	2.830	72.0
R12	.557	14.25	.710	18.0	.866	22.0	1.165	29.5
R14	.101	2.5	.100	2.5	.098	2.5	.118	3.0
R15	1.743	44.25	2.195	55.75	2.958	75.25	4.111	104.5

NOTES: \*\*TOLERANCE FOR DIMENSIONS: J = ± .0010 [±0.03] K = ± .0005 [±0.013] P (BETWEEN DOWEL PIN HOLES) = ± .0008 [±0.02]  
 F6 AND R6 = ± .0005 [±0.013] F3, R9, AND R10 = ± .0010 [±0.03] R8 = ± .005 [±0.13]

\*A CLOSED REFLECTS THE LARGEST POSSIBLE CLOSED DIMENSION.  
 A OPEN REFLECTS THE SMALLEST POSSIBLE OPEN DIMENSION.

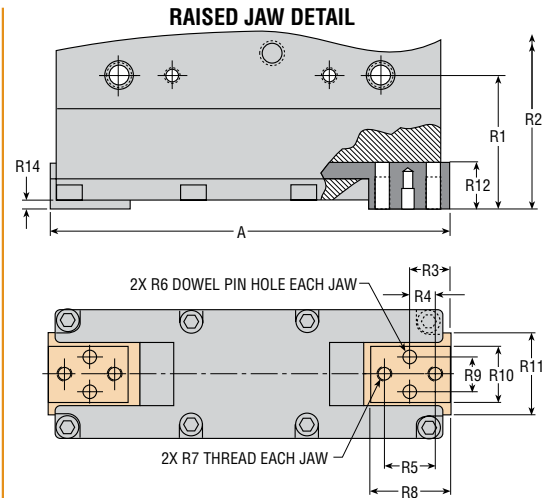
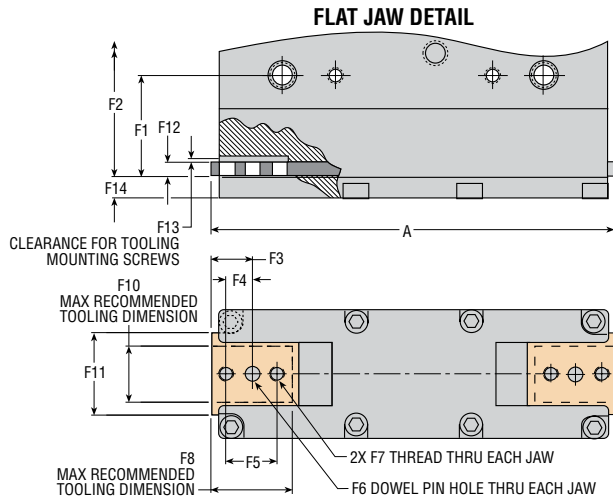

All dimensions are reference only unless specifically toleranced.

# SENSOR OPTIONS & ACCESSORIES: SERIES GRC GRIPPERS

2

## HALL EFFECT SWITCHES

This option equips the gripper with magnets on the rack for use with PHD Series 5360 Miniature Hall Effect Switches. These switches mount easily to the gripper using the “T” slot in the side of the body. Hall Effect Switches are ordered separately. No mounting kit required.

5

## INTERNAL PROXIMITY SWITCH READY

(SHURGRIP model only) This option equips the gripper for use with metal sensing proximity switches. The switch is inserted into a cavity in the housing and senses a steel pin attached to the jaw. The slotted switch bracket allows the proximity switches to be adjusted to sense the jaw positions. The bracket covers the opening so contaminants do not enter the cavity causing a false signal. Proximity Switches and mounting kit are ordered separately.

The lock housing is designed to accept the following size proximity switches:

- GRCx32** 4 mm Round Smooth
- GRCx42** 8 mm Threaded
- GRCx52** 8 mm Threaded
- GRCx62** 8 mm Threaded

	MODEL NUMBER			
	GRCx3x	GRCx4x	GRCx5x	GRCx6x
Mounting Kit	52309-02	52309-04	52309-06	52309-08

REFERENCE DIMENSIONS ARE APPROXIMATIONS ONLY. ACTUAL DIMENSIONS WILL BE BASED ON ACTUAL SENSING LOCATION.

EACH PROXIMITY SWITCH MOUNTING KIT CONTAINS:

- 2 SOCKET HEAD CAP SCREWS
- 1 PROXIMITY SWITCH BRACKET

6

## 12 mm EXTERNAL PROXIMITY SWITCH READY

(Full mounting style required) This option provides threaded mounting holes for mounting 12 mm metal sensing proximity switches. The customer is required to design and mount a metal target for the switch to sense. Proximity Switches and mounting kit are ordered separately.

	MODEL NUMBER			
	GRCx3x	GRCx4x	GRCx5x	GRCx6x
Mounting Kit	60512	60512	60512	60512

EACH PROXIMITY SWITCH MOUNTING KIT CONTAINS:

- 2 SOCKET HEAD CAP SCREWS
- 1 PROXIMITY SWITCH BRACKET

3&4

## MEDIUM DUTY SPRING ASSIST

5&6

## HEAVY DUTY SPRING ASSIST

(Full mounting style required) Springs can maintain spring grip force if air pressure is lost or increase grip force in one direction when used with air pressure. They can open or close the gripper without air pressure. Spring life in excess of 10 million cycles can be expected. For minimum operating pressures and spring forces, see specifications on page 4-51.

2&4

## SHURGRIP VERSION

(Licensed under U.S. Patent No. 4768821)

The SHURGRIP version of the PHD Series GRC Gripper is intended to maintain a friction lock to restrain jaw movement in the event of loss or removal of air pressure. This is accomplished through the use of an internal friction lock clutch. Repeated vibration or shock after loss or removal of air pressure may cause the jaws to open slightly. Care must be taken to design the tooling attached to the gripper jaws to encapsulate the part. The tooling should also have a slight “spring” or “deflection action” to retain tension on the gripper mechanism. PHD is not responsible for lack of part retention resulting from improper tooling or maintenance of the gripper.

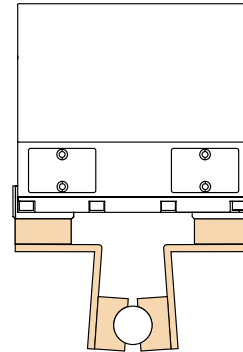

Options may affect unit length. See dimensional pages and option information details.



Refer to this product's online catalog in the product section for complete information including related dimensions and additional specifications. See link at bottom of this page.

# SENSOR OPTIONS & ACCESSORIES: SERIES GRC GRIPPERS

## 2 HALL EFFECT SWITCHES

This option equips the gripper with magnets on the rack for use with PHD Series 5360 Miniature Hall Effect Switches. These switches mount easily to the gripper using the "T" slot in the side of the body. Hall Effect Switches are ordered separately. No mounting kit required. See Switches and Sensors section for switch specifications.

PART NO.	DESCRIPTION
53603-1-02	NPN (Sink) 4.5-24 VDC, 2 meter cable
53604-1-02	PNP (Source) 4.5-24 VDC, 2 meter cable
53623-1	NPN (Sink) 4.5-24 VDC, Quick Connect
53624-1	PNP (Source) 4.5-24 VDC, Quick Connect

LETTER DIM.	MODEL NUMBER							
	GRCx3x		GRCx4x		GRCx5x		GRCx6x	
H1	.992	25.25	1.372	35.0	1.622	41.25	2.207	56.0
H2	.580	15.0	.580	15.0	.580	15.0	.580	15.0
H3	.224	5.75	.224	5.75	.224	5.75	.224	5.75
H4	.320	8.0	.320	8.0	.320	8.0	.320	8.0
H5	2.350	60.0	2.650	67.5	3.000	76.5	3.600	91.5

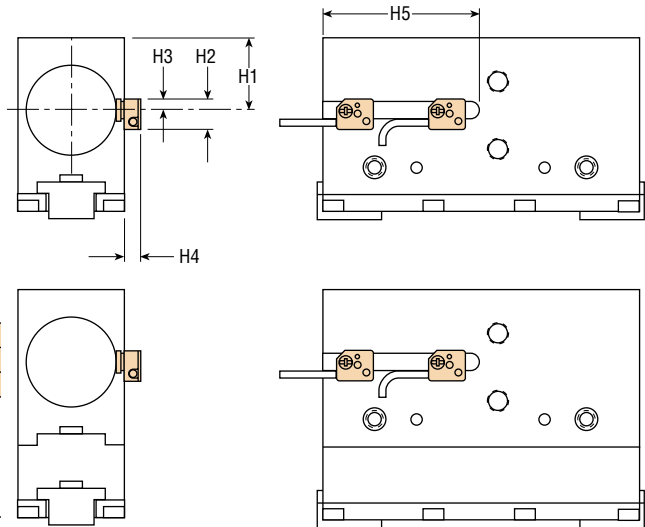

## 5 INTERNAL PROXIMITY SWITCH READY

(SHURGRIP model only) This option equips the gripper for use with metal sensing proximity switches. The switch is inserted into a cavity in the housing and senses a steel pin attached to the jaw. The slotted switch bracket allows the proximity switches to be adjusted to sense the jaw positions. The bracket covers the opening so contaminants do not enter the cavity causing a false signal.

Proximity Switches and mounting kit are ordered separately. See Switches and Sensors section for complete switch specifications.

The lock housing is designed to accept the following size proximity switches:

- GRCx32** 4 mm Round Smooth
- GRCx42** 8 mm Threaded
- GRCx52** 8 mm Threaded
- GRCx62** 8 mm Threaded

PART NO.	DESCRIPTION
18430-001-02	4 mm Round NPN (Sink) 2 m cable
18430-002-02	4 mm Round PNP (Source) 2 m cable
51422-005-02	8 mm Threaded NPN (Sink) 2 m cable
51422-006-02	8 mm Threaded PNP (Source) 2 m cable

### INSTALLATION

Adjust switch inward until it touches steel pin, then adjust outward .02 inch [0.5 mm] to set clear (do this with slide bracket in place). Adjust bracket to left or right to set switch position.

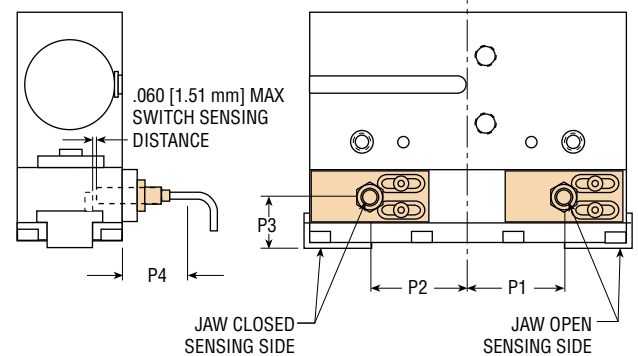

LETTER DIM.	MODEL NUMBER							
	GRCx3x		GRCx4x		GRCx5x		GRCx6x	
Mounting Kit	52309-02	52309-04	52309-06	52309-08				
P1	1.647	42.0	2.267	57.5	2.901	73.5	3.988	101.5
P2	.810	20.5	.455	11.5	1.300	33.0	1.971	50.0
P3	.675	17.0	1.078	27.5	1.247	31.5	1.537	39.0
P4	.576	14.5	1.042	26.5	1.042	26.5	1.042	26.5

REFERENCE DIMENSIONS ARE APPROXIMATIONS ONLY. ACTUAL DIMENSIONS WILL BE BASED ON ACTUAL SENSING LOCATION.

EACH PROXIMITY SWITCH MOUNTING KIT CONTAINS:  
 2 SOCKET HEAD CAP SCREWS  
 1 PROXIMITY SWITCH BRACKET

All dimensions are reference only unless specifically toleranced.

## 6 12 mm EXTERNAL PROXIMITY SWITCH READY

(Full mounting style required) This option provides threaded mounting holes for mounting 12 mm metal sensing proximity switches. The customer is required to design and mount a metal target for the switch to sense. Proximity Switches and mounting kit are ordered separately. See Switches and Sensors section for complete switch specifications.

PART NO.	DESCRIPTION
15561-001	NPN (Sink) 3 meter cable
15561-002	PNP (Source) 3 meter cable
15561-003	VAC Solid State

LETTER DIM.	MODEL NUMBER							
	GRCx3x		GRCx4x		GRCx5x		GRCx6x	
	in	mm	in	mm	in	mm	in	mm
Mounting Kit	60512		60512		60512		60512	
EP1	.851	21.5	1.383	35.0	1.560	39.5	3.311	84.0
EP2	1.250	32.0	1.250	32.0	1.250	32.0	1.250	32.0
EP3	.432	11.0	.432	11.0	.432	11.0	.432	11.0
EP4	.907	23.0	.907	23.0	.907	23.0	.907	23.0
EP5	1.476	37.5	2.008	51.0	2.185	55.5	3.937	100.0
EP6	.313	8.0	.313	8.0	.313	8.0	.313	8.0
EP7	.491	12.5	.751	19.1	1.203	30.5	1.048	26.6

EACH PROXIMITY SWITCH MOUNTING KIT CONTAINS:  
 2 SOCKET HEAD CAP SCREWS  
 1 PROXIMITY SWITCH BRACKET

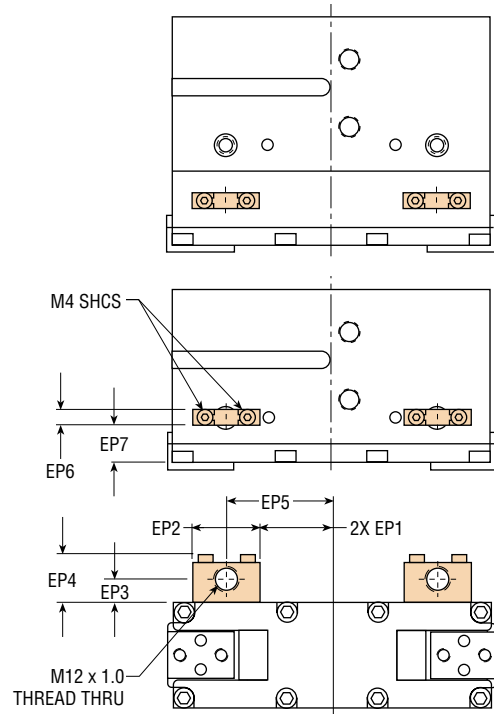

# SPRING OPTIONS: SERIES GRC PARALLEL GRIPPERS

## 3 & 4 MEDIUM DUTY SPRING ASSIST

## 5 & 6 HEAVY DUTY SPRING ASSIST

(Full mounting style required) Springs can maintain spring grip force if air pressure is lost or increase grip force in one direction when used with air pressure. They can open or close the gripper without air pressure. Spring life in excess of 10 million cycles can be expected. For minimum operating pressures and spring forces, see specifications on page 4-41.

LETTER DIM.	MODEL NUMBER							
	GRCx3x		GRCx4x		GRCx5x		GRCx6x	
S1	7.660	193.0	10.454	265.5	13.180	335.0	18.580	472.0
S2	.263	6.5	.387	9.75	.362	9.25	.356	9.0
S3	1.457	37.0	1.969	50.0	2.520	64.0	3.701	94.0
S4	1.536	39.0	2.008	51.0	2.598	66.0	3.818	97.0
S5	.086	2.25	.201	5.0	.199	5.0	.298	7.5
S6	1.812	46.0	2.341	59.5	2.846	72.25	3.818	97.0
S7	.315	8.0	.394	10.0	.394	10.0	.394	10.0
S8	.219	5.5	.307	7.75	.400	10.0	.400	10.0

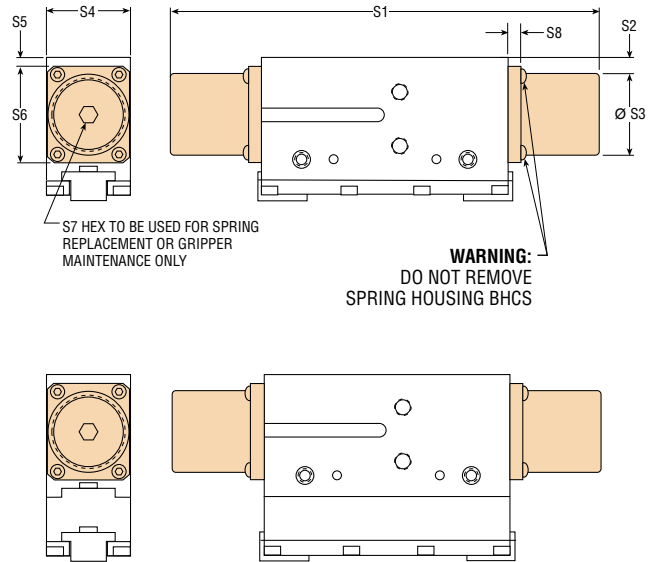

## 2 4 SHURGRIP VERSION (Licensed under U.S. Patent No. 4768821)

The SHURGRIP version of the PHD Series GRC Gripper is intended to maintain a friction lock to restrain jaw movement in the event of loss or removal of air pressure. This is accomplished through the use of an internal friction lock clutch. Repeated

vibration or shock after loss or removal of air pressure may cause the jaws to open slightly. Care must be taken to design the tooling attached to the gripper jaws to encapsulate the part. The tooling should also have a slight “spring” or “deflection action” to retain tension on the gripper mechanism. PHD is not responsible for lack of part retention resulting from improper tooling or maintenance of the gripper.

## MANUAL JAW OPERATION (SHURGRIP ONLY)

Rotating the hex in the rear of gripper moves jaws open or closed for easy switch setup and tooling adjustments without operating the valve.

LETTER DIM.	MODEL NUMBER							
	GRCx3x		GRCx4x		GRCx5x		GRCx6x	
HEX SIZE	5/32	4.0	5/32	4.0	5/16	8.0	5/16	8.0

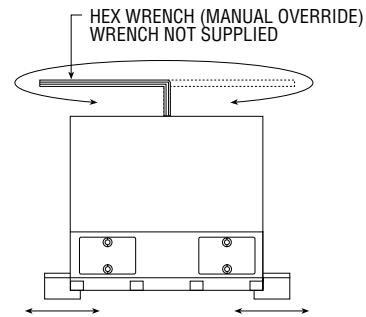

## SHURGRIP TOOLING

Care must be taken to design the tooling to encapsulate the part being grasped. On SHURGRIP versions, the tooling should have a slight “spring” or “deflection action” to retain tension on the gripper mechanism upon loss of air pressure.

PHD is not responsible for lack of part retention resulting from improper tooling or maintenance of the gripper.

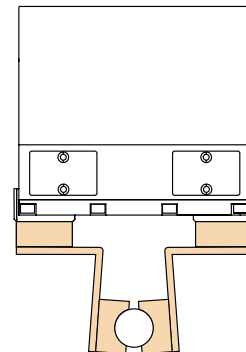

All dimensions are reference only unless specifically tolerated.